

Electric pallet stacker series-KLD



Suitable for single-sided/double-sided pallets



BRIEF INTRODUCTION OF PRODUCT

- ◎ Double linkage oil cylinder assembly, locking and lifting alternately.
- ◎ Three-position four-way valve oil circuit control system, lifting rod and fork linkage, cylinder body and machine body door seat linkage.
- ◎ When the movable door seat and fork move relative to each other, one component must be supported and positioned on the ground or carriage before it can move.
- ◎ Lightweight design concept, force balance fulcrum at the edge of the carriage, fork head adds counterweight, door column frame tail reduces weight, main components use stretching and hole turning process, force is reliable, strength is guaranteed.
- ◎ Swinging guide wheel is installed under the movable door seat to push the body into the carriage smoothly, which is convenient for maintenance and adjustment.
- ◎ Handrails are installed on both sides of the door frame, which makes it more convenient and quick to push and pull goods.
- ◎ It can follow the van and walk with the vehicle, and can realize self-loading and loading of the truck, which perfectly solves the problem of stacking and handling in the last ten meters of logistics distribution.

KLD-H Product Parameters

Model (型号)		KLD05-13HA	KLD10-13HA	
Performance (性能)	Maximum load capacity(负载能力)	kg	500	1000
	with load center at (载荷中心距)	mm	400	400
	Weight (with battery) (含电池重量)	kg	249	400
	Maximum lifting height (起升高度)	mm	1300	1300
	Lifting speed (without load)(无负载起升速度)	mm/s	140	65
	Lifting speed (with load) (负载起升速度)	mm/s	135	35
	Lowered speed (without load) (无负载下降速度)	mm/s	140	65
	Lowered speed (with load) (负载下降速度)	mm/s	145	35
Dimensions (尺寸)	Overall length of frame (整车长度)	mm	1569	1660
	Overall width of frame (整车宽度)	mm	885	885
	Max lowered height (门架降至最低整车高度)	mm	1595	1656
	Max height(max lifted with backrest (门架上升至最高整车高度)	mm	2860	2885
	Wheelbase (轴距)	mm	832	995
	Fork length (货叉长度)	mm	1115	1200
	Fork outside width (货叉外侧宽度)	mm	580	626
	Fork inside width (货叉内侧宽度)	mm	190	236
	Fork thickness (货叉厚度)	mm	60	70
	width of theoretical minimum aisle for right-angle stacking (1200x1000) (直角堆垛通道最小理论宽度)	mm	1200	1250
	Min frounf height (最小离地间隙)	mm	20	32
	Fork lowered height (货叉降至最低时高度)	mm	90	70
Minimum turning radius (最小转弯半径)	mm	1000	1300	
Tire (轮胎)	Front wheel (承载轮)	mm	80*50	80*50
电机	Type or drive motor (驱动电机类型)		直流电机	
	Rated output (功率)		0.75kw	
	Hoist motor type (起升电机类型)		直流电机	
	Rated output (功率)	kw	0.8	1.2
battery (电池)	Voltag (电压)	V	12	24
	Capacity (容量)	AH	45 (铅酸) /40 (锂电快换)	48

KLD05-13HA

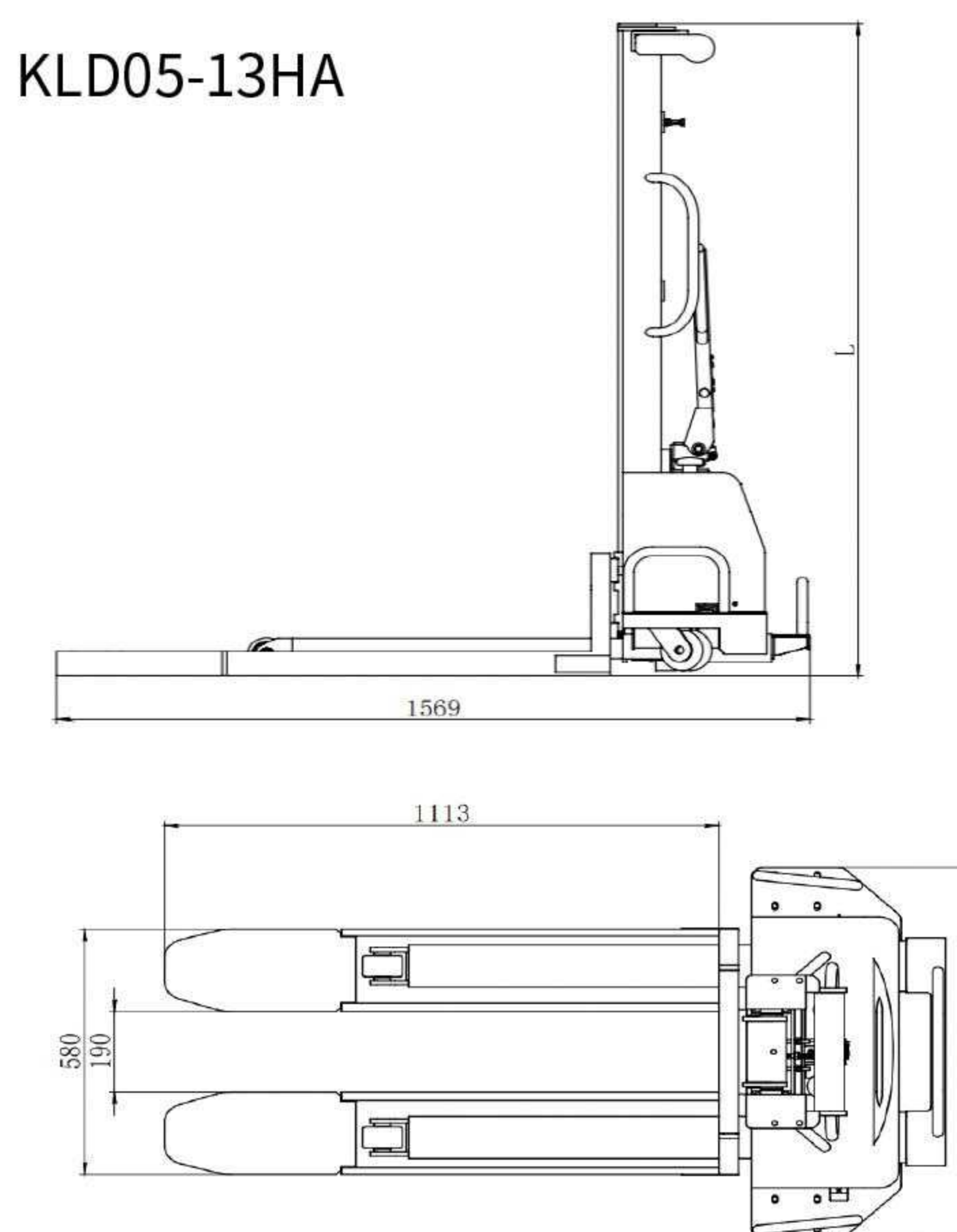

KLD10-13HA

