

Instructions for use of the Electric Pallet Stacker

(KLD-N, KLA06-E,KLA08-E, KLA08-H,KLA10, KLD10-N, KLD10-A, KLA12-E, KLA12-H, KLA12-J, KLA15, KLA15-H, KLA15-J, KLD15-EH, KLD15-ED, KLD15-N, KLD15-A,KLA20,KLD20-EA, KLD20-EC, KLD20-N, KLD20-A,KLD30)

Jiangsu King-lift Equipment.,Ltd.

You must understand this manual and various warning labels on the car before use. Pictures are for reference only, and the product is subject to the physical object.

2024VER.1

Preface

Welcome to use our company pallet stacker, the car is made of special profiles, compact design, durable, easy to operate. For your safety and correct operation, please understand the instructions and various warning labels on the car before use.

pay attention to:

All the parameters here are subject to the date of publication of this manual. We reserve the right to change our products without notice. If you want to know the latest product parameters, please contact us.

Explain

The forklift manufactured by our company is only used in the field (factory) in the factory area, tourist attractions, amusement places and other specific areas stipulated in the Special Equipment Safety Supervision Regulations.

Catalogue

1. Range of application.....	4
2. Operating steps.....	4
3. Safe code.....	37
4. Battery.....	39
5. Debugging.....	42
6. Maintenance.....	44
7. Electrical schematic diagram.....	47

1. Range of application

Electric pallet stacker are warehouse forklifts specifically designed for high-altitude stacking and peaceful transportation.

2. Operating steps

1. Brief description of the main parts and components

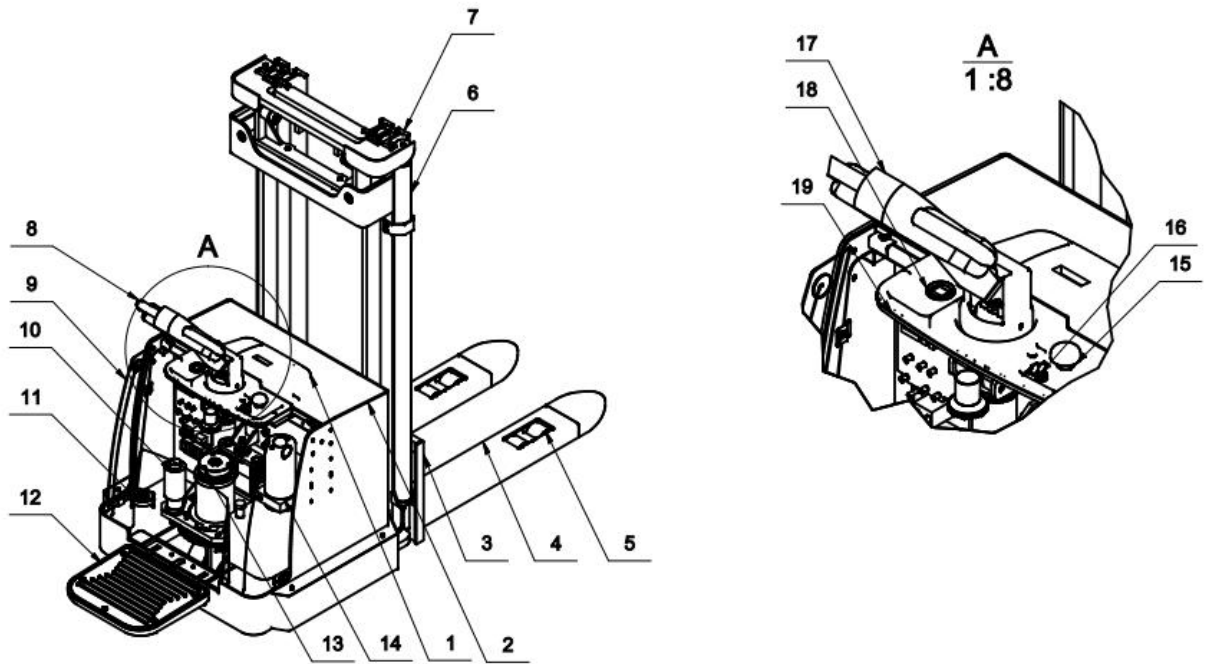
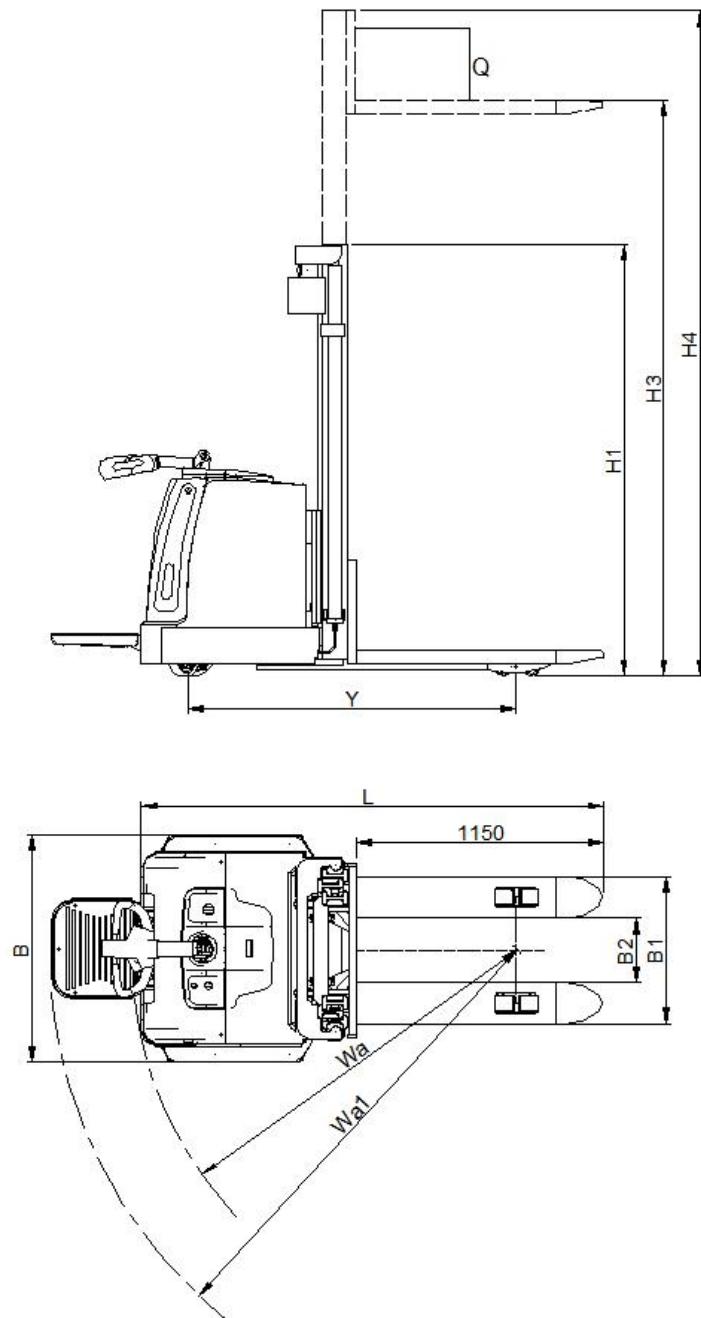

Figure 1

1	Battery box cover	9	The rear cover	17	Emergency stop reverse switch
2	Rack assembly	10	Steering motor	18	coulombmeter
3	Block shelves	11	Balanced wheel assembly	19	Handle shell
4	Fork	12	Platform		
5	Loading wheel	13	Drive motor assembly		
6	Hydraulic cylinder	14	power unit		
7	Mast assembly	15	emergency stop switch		
8	Steering handle	16	key switch		

2. Main technical parameters



Electric pallet stacker						
model				KLD15N	KLD20N	
func tion	load capacity		kg	1500	2000	
	Load center distance	Q	mm	600	600	
	lifting height	H3	mm	2500	2500	
	Travel speed (without load)		km/h	5.5	5.5	
	Travel speed (with load)		km/h	5	5	
	Lifting speed (without load)		mm/s	180	180	
	Lifting speed (with load)		mm/s	120	120	
	Lowering speed(without load)		mm/s	140	140	
	Lowering speed(with load)		mm/s	114	114	
	Gradeability(without load)		%	7	7	
	Gradeability(with load)		%	6	6	
	Service weight(with battery)		kg	1354	1354	
	size	Overall length of frame	L	mm	2138	2138
		Overall length of frame(with platform)		mm	2555	2555
Overall width of frame		B	mm	1046	1046	
Overall height when mast lowered to lowest		H1	mm	1734	1734	
Overall height when mast lifted to highest		H4	mm	2976	2976	
Wheelbase		Y	mm	1508	1508	
Fork length			mm	1150	1150	
Fork outside width		B1	mm	680	680	
Fork inside width		B2	mm	300	300	
Fork thickness			mm	65	65	
Fork height when fork lowered to lowest			mm	90	90	
Minimum ground clearance			mm	20	20	
1200x1000		Asts	mm	2470	2470	

	Minimum turning radius	Wa	mm	1800	1800
	Minimum turning radius (with platform)	Wa1	mm	2175	2175
tyre	Front (load) wheel		mm	85*70	85*70
	Driving wheel		mm	230*75	230*75
	Caster wheel		mm	130*55	130*55
	wheel type	polyurethane			
Pow er form	Type of drive motor	a-c dynamo			
	Rated output		kw	1.5	1.5
	Type of lift motor	continuous current dynamo			
	Rated output		kw	3	3
Batt ery	voltage		V	24	
	capacity		AH	210	
	weight		kg	195	

Mast type	Max fork height	Mast lowered	Mast extended
	KLD15N/20N	KLD15N/20N	KLD15N/20N
Duplex mast (2 stage)	2500	1734	2976
	3000	1984	3476
	3500	2234	3976
	4000	2484	4476
Triplex mast (3 stage)	4000	1814	4496
	4500	1984	4966
	5000	2154	5476
	5500	2314	5956
	6000	2484	6436

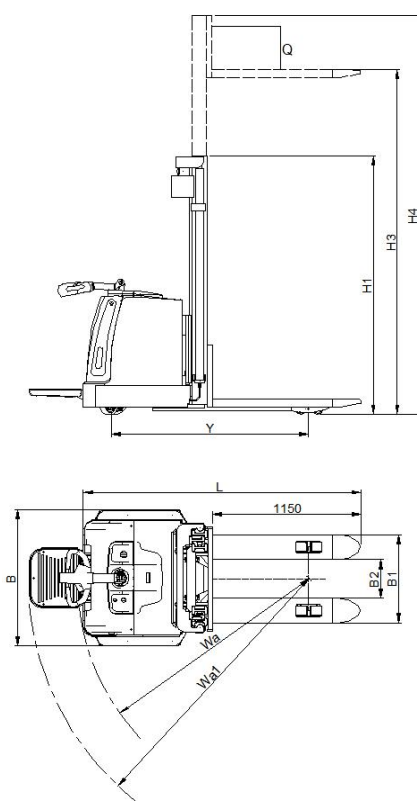

KLD15N/20N Electric pallet stacker

Model (型号)				KLD1 5N	KLD2 0N
Performance (性能)	Maximum load capacity(负载能力)		kg	1500	2000
	load center (载荷中心距)	Q	mm	600	600
	Maximum lifting height (起升高度)	H3	mm	2500	2500
	Travel speed (without load) (无负载行驶速度)		km/h	5.5	5.5
	Travel speed (with load) (负载行驶速度)		km/h	5	5
	Lifting speed (without load)(无负载起升速度)		mm/s	180	180
	Lifting speed (with load) (负载起升速度)		mm/s	120	120
	Lowering speed (without load) (无负载下降速度)		mm/s	140	140
	Lowering speed (with load) (负载下降速度)		mm/s	114	114
	Gradeability (without load) (无负载最大爬坡能力)		%	7	7
	Gradeability (with load) (负载最大爬坡能力)		%	6	6
Service Weight (with battery) (重量含电池)		kg	1354	1354	
Dimensions (尺寸)	Overall length of frame (整车长度)	L	mm	2138	2138
	Overall length of frame(with platform)(整车长度带踏板)		mm	2555	2555
	Overall width of frame (整车宽度)	B	mm	1046	1046
	Overall height when mast lowered to lowest (门架降至最低整车高度)	H1	mm	1734	1734
	Overall height when mast lifted to highest (门架上升至最)	H4	mm	2976	2976

	高整车高度)					
	Wheelbase (轴距)		Y	mm	1508	1508
	Fork length (货叉长度)			mm	1150	1150
	Fork outside width (货叉外侧宽度)		B1	mm	680	680
	Fork inside width (货叉内侧宽度)		B2	mm	300	300
	Fork thickness (货叉厚度)			mm	65	65
	Fork height when fork lowered to lowest (货叉降至最低高度)			mm	90	90
	Min ground clearance (最小离地间隙)			mm	20	20
	Theoretical width of minimum aisle for right-angle stacking (1200x1000) (直角堆垛通道最小理论宽度)		Ast s	mm	2470	2470
	Minimum turning radius (without platform) (不带踏板最小转弯半径)		Wa	mm	1800	1800
	Minimum turning radius (with platform) (带踏板最小转弯半径)		Wa 1	mm	2175	2175
	Tire(轮胎)	Front wheel (承载轮)			mm	85*70
Drive wheel (驱动轮)			mm	230*7 5	230*7 5	
Caster wheel (平衡轮)			mm	130*5 5	130*5 5	
Wheel material (车轮类型)		polyurethane (聚氨酯)				
Electrical components (动力形式)	Drive motor type (驱动电机类型)		AC series motor (交流电机)			
	Rated output (功率)			kw	1.5	1.5
	Hoist motor type (起升电机类型)		DC series motor (直流电机)			
	Rated output (功率)			kw	3	3
Battery (电池)	Voltag (电压)			V	24	
	Capacity (容量)			AH	210	
	Weight (重量)			kg	195	
Mast type (门架类型)	Max fork height (货叉最大高度)	Mast lowered (门架降低时高度)	Mast extended (门架延伸时高度)			
	KLD15N/20N	KLD15N/20N	KLD15N/20N			
Simplex or Duplex mast (2Stage)2级门架	2500	1734	2976			
	3000	1984	3476			
	3500	2234	3976			
	4000	2484	4476			
Triplex mast (3Stage)3级门架	4000	1814	4496			
	4500	1984	4966			
	5000	2154	5476			
	5500	2314	5956			
	6000	2484	6436			

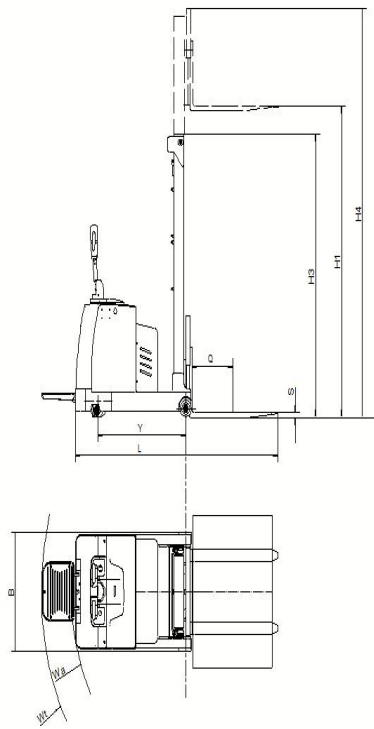

KLA06/08/12/15-E Electric pallet stacker

Model (型号)			KLA 06E	KLA 08E	KLA 12E	KLA 15E	
Perform ance (性 能)	Maximum load capacity(负载能力)		kg	600	800	1200	1500
	load center(载荷中心距)	Q	m m	500	500	500	500
	Maximum lifting height (起升高度)	H3	m m	1600	1600	1600	1600
	Travel speed (without load) (无负载行驶速度)		km /h	5.5	5.5	5.5	5.5
	Travel speed (with load) (负载行驶速度)		km /h	5	5	5	5
	Lifting speed (without load) (无负载起升速度)		m m/ s	121	121	121	174
	Lifting speed (with load)(负载起升速度)		m m/ s	81	81	81	101
	lowering speed(without load) (无负载下降速度)		m m/ s	105	105	105	152
	Lowering speed (with load) (负载下降速度)		m m/ s	103	103	103	150
	Gradeability (without load) (无负载最大爬坡能力)		%	7	7	7	7
	Gradeability (with load)(负载最大爬坡能力)		%	6	6	6	6
	Service weight (with battery) (重量含电池)		kg	1495	1707	1712	≈1450

Dimensions (尺寸)	Overall length of frame(整车长度)	L	m	2395	2395	2515	3066
	Overall length of frame(with platform)(整车长度带踏板)		m	2810	2810	2930	3486
	Overall width of frame (整车宽度)	B	m	940	940	940	940
	Overall height when Mast lowered to lowest (门架降至最低整车高度)	H1	m	2095	2095	2095	2095
	Overall height when Mast lifted to highest (门架升至最高整车高度)	H4	m	2366	2366	2366	2366
	Wheelbase (轴距)	Y	m	930	930	1050	1630
	Fork length (货叉长度)		m	1070	1070	1070	1070
	Fork spread width (货叉外侧宽度可调范围)		m	210-670	210-670	210-670	210-670
	Fork width (货叉面宽度)		m	100	100	100	100
	Fork height when fork lowered to lowest(货叉降至最低高度)	S	m	60	60	60	60
	Min ground clearance (最小离地间隙)		m	55	55	55	45
	Theoretical width of minimum aisle for right-angle stacking (1200x1000) (直角堆垛通道最小理论宽度)	As	m	2498	2498	2615	3195
	Minimum turning radius (without platform)(不带踏板最小转弯半径)	Wa	m	1147	1147	1260	1952
	Minimum turning radius (with platform) (带踏板最小转弯半径)	Wa1	m	1625	1625	1740	2340
	Tyre (轮胎)	Front wheel(承载轮)		m	210* 85	210* 85	210* 85
Drive wheel(驱动轮)			m	230* 75	230* 75	230* 75	250* 80
Caster wheel (平衡轮)			m	130* 55	130* 55	130* 55	140* 80
Wheel material (车轮类型)		polyurethane (聚氨酯)					
Electrical components (动力形式)	Drive motor type (驱动电机类型)	AC series motor(交流电机)					
	Rated output (功率)		kw	1.5	1.5	1.5	1.5
	Hoist motor type (起升电机类型)	DC series motor (直流电机)					
	Rated output (功率)		kw	2.2	2.2	2.2	2.2
Battery (电池)	Voltage (电压)		V	24			24
	Capacity (容量)		AH	210			210
	Weight (重量)		kg	195			195
Mast type (门架类型)	Max fork height (货叉最大高度)	Mast lowered (门架降低时高度)	Mast extended (门架延伸时高度)				

	KLA06/08/12E	KLA06/08/12E	KLA06/08/12E
Simplex or Duplex mast (2Stage)2 级门架	2000	1485	2766
	2500	1735	3266
	3000	1985	3766
	3500	2235	4266
	4000	2485	4766

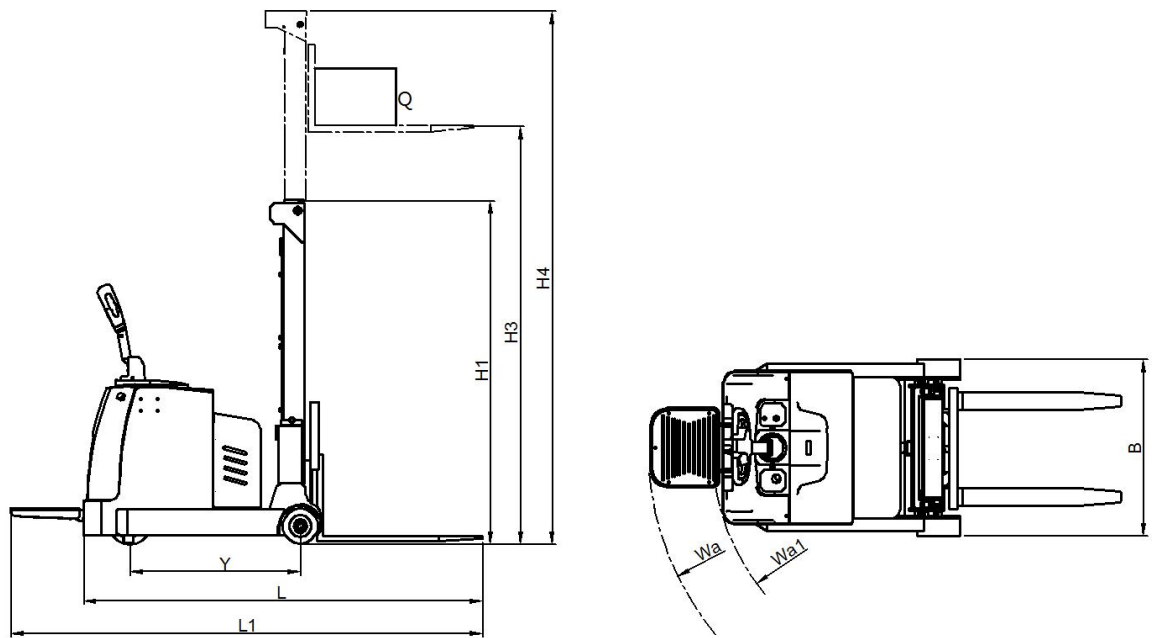

KLA08H/12H/15H Counterbalanced electric pallet stacker

Model (型号)				KLA0 8H	KLA1 2H	KLA1 5H
Performance (性能)	Maximum load capacity(负载能力)		kg	800	1200	1500
	load center(载荷中心距)	Q	mm	500	500	500
	Maximum lifting height (起升高度)	H3	mm	1600	1600	1600
	Travel speed (without load) (无负载行驶速度)		km/h	5.5	5.5	5.5
	Travel speed (with load) (负载行驶速度)		km/h	5	5	5
	Lifting speed (without load) (无负载起升速度)		mm/s	121	121	121
	Lifting speed (with load)(负载起升速度)		mm/s	81	81	81
	lowering speed(without load) (无负载下降速度)		mm/s	105	105	105
	Lowering speed (with load) (负载下降速度)		mm/s	103	103	103
	Gradeability (without load) (无负载最大爬坡能力)		%	7	7	7
	Gradeability (with load)(负载最大爬坡能力)		%	6	6	6
	Service weight (with battery) (重量含电池)		kg	1452	1784	1810
Dimensions (尺寸)	Overall length of frame(整车长度)	L	mm	2460	2525	2904
	Overall length of frame(with platform)(整车长度带踏板)	L1	mm	2880	2945	3323
	Overall width of frame (整车宽度)	B	mm	1020	1020	1020
	Overall height when Mast lowered to lowest (门架降至最低整车高度)	H1	mm	2095	2095	2095
	Overall height when Mast lifted to highest (门架上升至最高整车高度)	H4	mm	2412	2412	2412

	Wheelbase (轴距)	Y	mm	986	1050	1430
	Fork length (货叉长度)		mm	1070	1070	1070
	Fork spread width (货叉外侧宽度可调范围)		mm	210-670	210-670	210-670
	Fork width (货叉面宽度)		mm	100	100	100
	Fork height when fork lowered to lowest(货叉降至最低高度)	S	mm	60	60	60
	Min ground clearance (最小离地间隙)		mm	55	55	55
	Theoretical width of minimum aisle for right-angle stacking (1200x1000) (直角堆垛通道最小理论宽度)	Ast s	mm	2600	2660	3026
	Minimum turning radius (without platform) (不带踏板最小转弯半径)	W a	mm	1340	1400	1766
	Minimum turning radius (with platform) (带踏板最小转弯半径)	W a1	mm	1710	1770	2146
Tyre (轮胎)	Front wheel(承载轮)		mm	210*85	210*85	210*85
	Drive wheel(驱动轮)		mm	250*80	250*80	250*80
	Caster wheel (平衡轮)		mm	130*55	130*55	130*55
	Wheel material (车轮类型)	polyurethane (聚氨酯)				
Electrical components (动力形式)	Drive motor type (驱动电机类型)	AC series motor(交流电机)				
	Rated output (功率)		kw	1.5	1.5	1.5
	Hoist motor type (起升电机类型)	DC series motor (直流电机)				
	Rated output (功率)		kw	2.2	2.2	2.2
Battery (电池)	Voltage (电压)		V	24		
	Capacity (容量)		AH	160		
	Weight (重量)		kg	150		

Mast type (门架类型)	Max fork height (货叉最大高度)	Mast lowered (门架降低时高度)	Mast extended (门架延伸时高度)
	KLA08H/12H/15H	KLA08H/12H/15H	KLA08H/12H/15H
Simplex or Duplex mast (2Stage)2级门架	2000	1495	2782
	2500	1745	3282
	3000	1995	3782
	3500	2245	4282

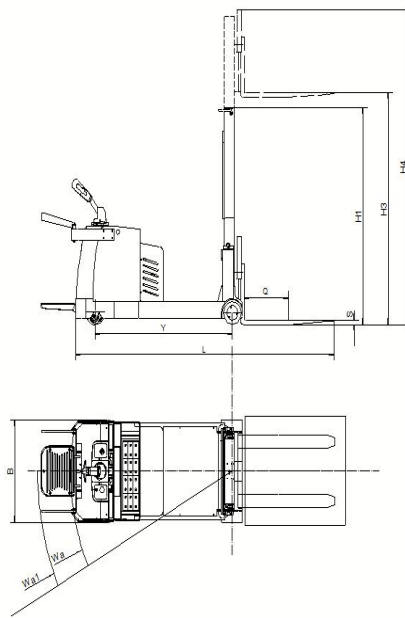

KLA10/15/20 Counterbalanced electric pallet stacker

Model (型号)				KLA10	KLA15	KLA20
Performance (性能)	Maximum load capacity(负载能力)		kg	1000	1500	2000
	load center(载荷中心距)	Q	mm	500	500	600
	Maximum lifting height (起升高度)	H3	mm	1600	1600	1600
	Travel speed (without load) (无负载行驶速度)		km/h	5.5	5.5	5.5
	Travel speed (with load) (负载行驶速度)		km/h	5	5	5
	Lifting speed (without load) (无负载起升速度)		mm/s	121	121	121
	Lifting speed (with load)(负载起升速度)		mm/s	81	81	81
	lowering speed(without load) (无负载下降速度)		mm/s	105	105	105
	Lowering speed (with load) (负载下降速度)		mm/s	103	103	103
	Gradeability (without load) (无负载最大爬坡能力)		%	7	7	7
	Gradeability (with load)(负载最大爬坡能力)		%	6	6	6
	Service weight (with battery) (重量含电池)		kg	1596	1696	1796
Dimensions (尺寸)	Overall length of frame(整车长度)	L	mm	3160	3160	3160
	Overall length of frame(with platform)(整车长度带踏板)		mm	3486	3486	3486
	Overall width of frame (整车宽度)	B	mm	940	940	940
	Overall height when Mast lowered to lowest (门架降至最低整车高度)	H1	mm	2095	2095	2095
	Overall height when Mast lifted to highest (门架升至最高整车高度)	H4	mm	2366	2366	2366
	Wheelbase (轴距)	Y	mm	1630	1630	1630

	Fork length (货叉长度)		mm	1070	1070	1070
	Fork spread width (货叉外侧宽度可调范围)		mm	210-670	210-670	210-670
	Fork width (货叉面宽度)		mm	100	100	100
	Fork height when fork lowered to lowest(货叉降至最低高度)	S	mm	60	60	65
	Min ground clearance (最小离地间隙)		mm	55	55	55
	Theoretical width of minimum aisle for right-angle stacking (1200x1000) (直角堆垛通道最小理论宽度)	Ast s	mm	3360	3360	3360
	Minimum turning radius (without platform) (不带踏板最小转弯半径)	Wa	mm	1925	1925	1925
	Minimum turning radius (with platform) (带踏板最小转弯半径)	Wa 1	mm	2320	2320	2320
Tyre (轮胎)	Front wheel(承载轮)		mm	210*85	210*85	210*85
	Drive wheel(驱动轮)		mm	230*75	230*75	230*75
	Caster wheel (平衡轮)		mm	130*55	130*55	130*55
	Wheel material (车轮类型)	polyurethane (聚氨酯)				
Electrical components (动力形式)	Drive motor type (驱动电机类型)	AC series motor(交流电机)				
	Rated output (功率)		kw	1.5	1.5	1.5
	Hoist motor type (起升电机类型)	DC series motor (直流电机)				
	Rated output (功率)		kw	2.2	2.2	2.2
Battery (电池)	Voltage (电压)		V	24		
	Capacity (容量)		AH	210		
	Weight (重量)		kg	195		

Mast type (门架类型)	Max fork height (货叉最大高度)	Mast lowered (门架降低时高度)	Mast extended (门架延伸时高度)
	KLA10/15/20	KLA10/15/20	KLA10/15/20
Simplex or Duplex mast (2Stage)2 级门架	2000	1485	2766
	2500	1735	3266
	3000	1985	3766
	3500	2235	4266
	4000	2485	4766

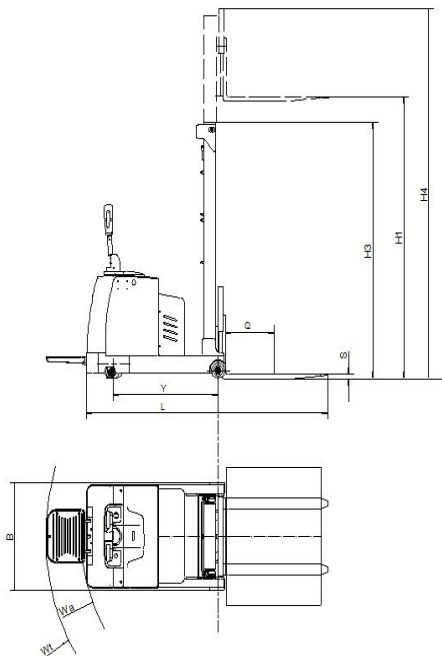

KLA12J Counterbalanced electric pallet stacker

Model (型号)				KLA12 J	KLA15 J
Performance (性能)	Maximum load capacity(负载能力)		kg	1200	1500
	load center(载荷中心距)	Q	mm	500	500
	Maximum lifting height (起升高度)	H3	mm	1600	1600
	Travel speed (without load) (无负载行驶速度)		km/h	5.5	5.5
	Travel speed (with load) (负载行驶速度)		km/h	5	5
	Lifting speed (without load) (无负载起升速度)		mm/s	174	174
	Lifting speed (with load)(负载起升速度)		mm/s	101	101
	lowering speed(without load) (无负载下降速度)		mm/s	152	152
	Lowering speed (with load) (负载下降速度)		mm/s	150	150
	Gradeability (without load) (无负载最大爬坡能力)		%	7	7
	Gradeability (with load)(负载最大爬坡能力)		%	6	6
Service weight (with battery) (重量含电池)		kg	≈1405	≈1450	
Dimensions (尺寸)	Overall length of frame(整车长度)	L	mm	2536	3066
	Overall length of frame(with platform)(整车长度带踏板)		mm	2956	3486
	Overall width of frame (整车宽度)	B	mm	940	940
	Overall height when Mast lowered to lowest (门架降至最低整车高度)	H1	mm	2095	2095
	Overall height when Mast lifted to highest (门架升至最高整车高度)	H4	mm	2366	2366
	Wheelbase (轴距)	Y	mm	1100	1630

	Fork length (货叉长度)		mm	1070	1070
	Fork spread width (货叉外侧宽度可调范围)		mm	210-670	210-670
	Fork width (货叉面宽度)		mm	100	100
	Fork height when fork lowered to lowest(货叉降至最低高度)	S	mm	60	60
	Min ground clearance (最小离地间隙)		mm	45	45
	Theoretical width of minimum aisle for right-angle stacking (1200x1000) (直角堆垛通道最小理论宽度)	Ast s	mm	2678	3195
	Minimum turning radius (without platform) (不带踏板最小转弯半径)	Wa	mm	1438	1952
	Minimum turning radius (with platform)(带踏板最小转弯半径)	Wa 1	mm	1810	2340
Tyre(轮胎)	Front wheel(承载轮)		mm	140*80	140*80
	Drive wheel(驱动轮)		mm	250*80	250*80
	Caster wheel (平衡轮)		mm	140*80	140*80
	Wheel material (车轮类型)	polyurethane (聚氨酯)			
Electrical components (动力形式)	Drive motor type (驱动电机类型)	AC series motor(交流电机)			
	Rated output (功率)		kw	1.5	
	Hoist motor type (起升电机类型)	DC series motor (直流电机)			
	Rated output (功率)		kw	2.2	
Battery (电池)	Voltage (电压)		V	24	
	Capacity (容量)		AH	100	
	Weight (重量)		kg	35	

Mast type (门架类型)	Max fork height (货叉最大高度)	Mast lowered (门架降低时高度)	Mast extended (门架延伸时高度)
		KLA-J	KLA-J
Simplex or Duplex mast (2Stage)2级门架	2000	1485	2766
	2500	1735	3266
	3000	1985	3766
	3500	2235	4266

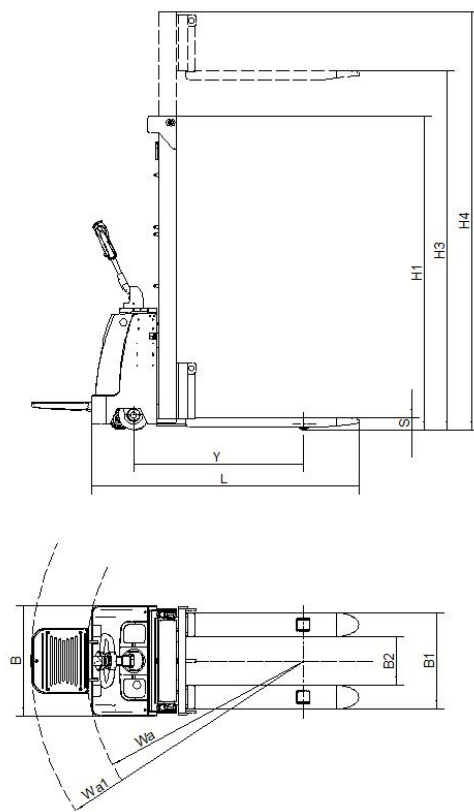

KLD15EH Electric pallet stacker

Model (型号)				KLD15EH
Performance (性能)	Maximum load capacity(负载能力)		kg	1500
	load center (载荷中心距)	Q	mm	600
	Maximum lifting height (起升高度)	H3	mm	1600
	Travel speed (without load) (无负载行驶速度)		km/h	3.8
	Travel speed (with load) (负载行驶速度)		km/h	3.4
	Lifting speed (without load)(无负载起升速度)		mm/s	163
	Lifting speed (with load) (负载起升速度)		mm/s	113
	Lowering speed (without load) (无负载下降速度)		mm/s	105
	Lowering speed (with load) (负载下降速度)		mm/s	113
	Gradeability (without load) (无负载最大爬坡能力)		%	\
	Gradeability (with load) (负载最大爬坡能力)		%	\
	Service Weight (with battery) (重量含电池)		kg	~490
	Dimensions (尺寸)	Overall length of frame (整车长度)	L	mm
Overall length of frame(with platform)(整车长度带踏板)			mm	2300
Overall width of frame (整车宽度)		B	mm	782
Overall height when mast lowered to lowest (门架降至最低整车高度)		H1	mm	2090
Overall height when mast lifted to highest (门架上升至最高整车高度)		H4	mm	2090
Wheelbase (轴距)		Y	mm	1198
Fork length (货叉长度)			mm	1150
Fork outside width (货叉外侧宽度)		B1	mm	680
Fork inside width (货叉内侧宽度)		B2	mm	340
Fork thickness (货叉厚度)		mm	65	

	Fork height when fork lowered to lowest (货叉降至最低高度)	S	mm	90
	Min ground clearance (最小离地间隙)		mm	15
	Theoretical width of minimum aisle for right-angle stacking (1200x1000) (直角堆垛通道最小理论宽度)	Asts	mm	2202
	Minimum turning radius (without platform) (不带踏板最小转弯半径)	Wa	mm	1532
	Minimum turning radius (with platform) (带踏板最小转弯半径)	Wa1	mm	1919
Tire (轮胎)	Front wheel (承载轮)		mm	85*70
	Drive wheel (驱动轮)		mm	210*75
	Caster wheel (平衡轮)		mm	130*50
	Wheel material (车轮类型)	polyurethane (聚氨酯)		
Electrical components (动力形式)	Drive motor type (驱动电机类型)	DC series motor (直流电机)		
	Rated output (功率)		kw	0.75
	Hoist motor type (起升电机类型)	DC series motor (直流电机)		
	Rated output (功率)		kw	2.2
Battery (电池)	Voltage (电压)		V	24
	Capacity (容量)		AH	80
	Weight (重量)		kg	26

Mast type (门架类型)	Max fork height (货叉最大高度)	Mast lowered (门架降低时高度)	Mast extended (门架延伸时高度)
		KLD15EH	KLD15EH
Simplex or Duplex mast (2Stage)2级门架	2000	1480	2460
	2500	1730	2960
	3000	1980	3460
	3500	2230	3960

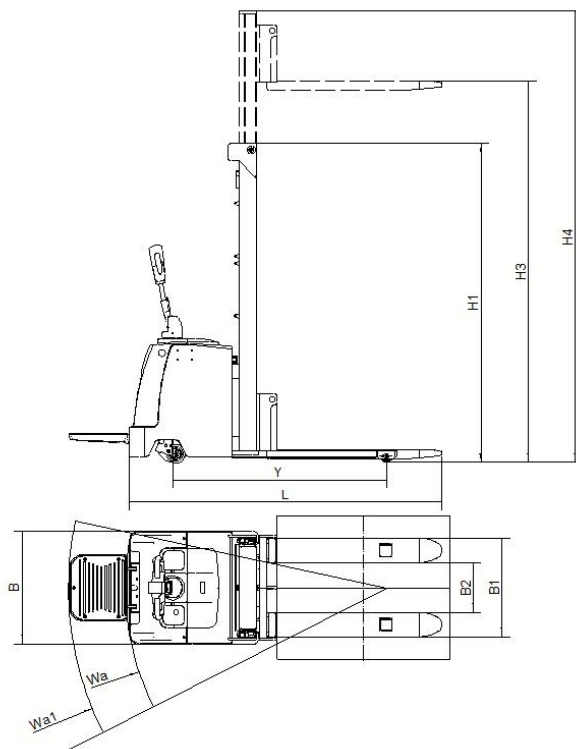

KLD15ED Electric pallet stacker

Model (型号)				KLD15ED
Performance (性能)	Maximum load capacity(负载能力)		kg	1500
	load center (载荷中心距)	Q	mm	600
	Maximum lifting height (起升高度)	H3	mm	1600
	Travel speed (without load) (无负载行驶速度)		km/h	4.1
	Travel speed (with load) (负载行驶速度)		km/h	3.7
	Lifting speed (without load)(无负载起升速度)		mm/s	121
	Lifting speed (with load) (负载起升速度)		mm/s	81
	Lowering speed (without load) (无负载下降速度)		mm/s	105
	Lowering speed (with load) (负载下降速度)		mm/s	103
	Gradeability (without load) (无负载最大爬坡能力)		%	\
	Gradeability (with load) (负载最大爬坡能力)		%	\
	Service Weight (with battery) (重量含电池)		kg	640
	Dimensions (尺寸)	Overall length of frame (整车长度)	L	mm
Overall length of frame(with platform)(整车长度带踏板)			mm	2590
Overall width of frame (整车宽度)		B	mm	854
Overall height when mast lowered to lowest (门架降至最低整车高度)		H1	mm	2090
Overall height when mast lifted to highest (门架上升至最高整车高度)		H4	mm	2090
Wheelbase (轴距)		Y	mm	1480
Fork length (货叉长度)			mm	1150
Fork outside width (货叉外侧宽度)		B1	mm	680
Fork inside width (货叉内侧宽度)		B2	mm	340
Fork thickness (货叉厚度)		mm	65	

	Fork height when fork lowered to lowest (货叉降至最低高度)	S	mm	90
	Min ground clearance (最小离地间隙)		mm	15
	Theoretical width of minimum aisle for right-angle stacking (1200x1000) (直角堆垛通道最小理论宽度)	Asts	mm	2490
	Minimum turning radius (without platform) (不带踏板最小转弯半径)	Wa	mm	1813
	Minimum turning radius (with platform) (带踏板最小转弯半径)	Wa1	mm	2207
Tire (轮胎)	Front wheel (承载轮)		mm	85*70
	Drive wheel (驱动轮)		mm	210*75
	Caster wheel (平衡轮)		mm	130*50
	Wheel material (车轮类型)	polyurethane (聚氨酯)		
Electrical components (动力形式)	Drive motor type (驱动电机类型)	AC series motor (交流电机)		
	Rated output (功率)		kw	0.75
	Hoist motor type (起升电机类型)	DC series motor (直流电机)		
	Rated output (功率)		kw	2.2
Battery (电池)	Voltage (电压)		V	24
	Capacity (容量)		AH	100
	Weight (重量)		kg	35

Mast type (门架类型)	Max fork height (货叉最大高度)	Mast lowered (门架降低时高度)	Mast extended (门架延伸时高度)
	KLD15ED	KLD15ED	KLD15ED
Simplex or Duplex mast (2Stage)2级门架	2000	1480	2460
	2500	1730	2960
	3000	1980	3460
	3500	2230	3960
	4000	2480	4460

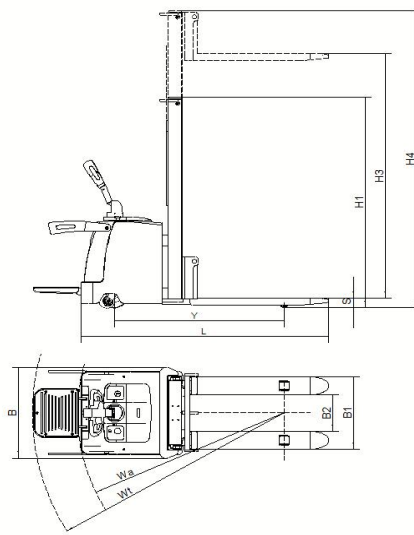

KLD20EA Electric pallet stacker

Model (型号)				KLD20EA
Performance (性能)	Maximum load capacity(负载能力)		kg	2000
	load center (载荷中心距)	Q	mm	600
	Maximum lifting height (起升高度)	H3	mm	1600
	Travel speed (without load) (无负载行驶速度)		km/h	5.5
	Travel speed (with load) (负载行驶速度)		km/h	5
	Lifting speed (without load)(无负载起升速度)		mm/s	121
	Lifting speed (with load) (负载起升速度)		mm/s	81
	Lowering speed (without load) (无负载下降速度)		mm/s	105
	Lowering speed (with load) (负载下降速度)		mm/s	103
	Gradeability (without load) (无负载最大爬坡能力)		%	7
	Gradeability (with load) (负载最大爬坡能力)		%	6
	Service Weight (with battery) (重量含电池)		kg	850
Dimensions (尺寸)	Overall length of frame (整车长度)	L	mm	2172
	Overall length of frame(with platform)(整车长度带踏板)		mm	2590
	Overall width of frame (整车宽度)	B	mm	854
	Overall height when mast lowered to lowest (门架降至最低整车高度)	H1	mm	2090
	Overall height when mast lifted to highest (门架上升至最高整车高度)	H4	mm	2090
	Wheelbase (轴距)	Y	mm	1420
	Fork length (货叉长度)		mm	1150
	Fork outside width (货叉外侧宽度)	B1	mm	680
	Fork inside width (货叉内侧宽度)	B2	mm	300
	Fork thickness (货叉厚度)		mm	65
	Fork height when fork lowered to lowest (货叉降至最低高度)	S	mm	90
	Min ground clearance (最小离地间隙)		mm	15
	Theoretical width of minimum aisle for right-angle stacking (1200x1000) (直角堆垛通道最小理论宽度)	Asts	mm	2490
	Minimum turning radius (without platform) (不带踏板最小转弯半径)	Wa	mm	1813

	Minimum turning radius (with platform) (带踏板最小转弯半径)	Wa1	mm	2207
Tire (轮胎)	Front wheel (承载轮)		mm	85*70
	Drive wheel (驱动轮)		mm	250*80
	Caster wheel (平衡轮)		mm	130*55
	Wheel material (车轮类型)	polyurethane (聚氨酯)		
Electrical components (动力形式)	Drive motor type (驱动电机类型)	AC series motor (交流电机)		
	Rated output (功率)		kw	1.5
	Hoist motor type (起升电机类型)	DC series motor (直流电机)		
	Rated output (功率)		kw	2.2
Battery (电池)	Voltage (电压)		V	24
	Capacity (容量)		AH	160
	Weight (重量)		kg	150

Mast type (门架类型)	Max fork height (货叉最大高度)	Mast lowered (门架降低时高度)	Mast extended (门架延伸时高度)
	KLD20EA	KLD20EA	KLD20EA
Simplex or Duplex mast (2Stage)2级门架	2000	1480	2460
	2500	1730	2960
	3000	1980	3460
	3500	2230	3960
	4000	2480	4460

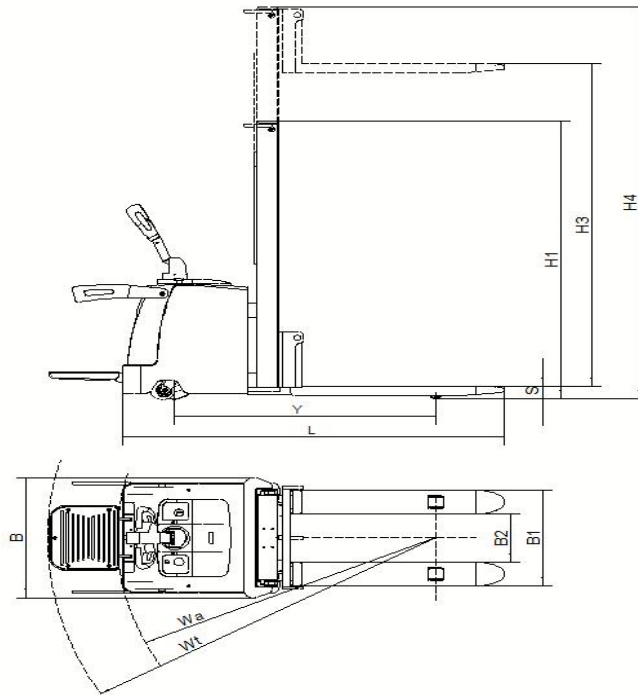

KLD20EC Electric pallet stacker

Model (型号)				KLD20EC
Performance (性能)	Maximum load capacity(负载能力)		kg	2000
	load center (载荷中心距)	Q	mm	600
	Maximum lifting height (起升高度)	H3	mm	1600
	Travel speed (without load) (无负载行驶速度)		km/h	5.5
	Travel speed (with load) (负载行驶速度)		km/h	5
	Lifting speed (without load)(无负载起升速度)		mm/s	121
	Lifting speed (with load) (负载起升速度)		mm/s	81
	Lowering speed (without load) (无负载下降速度)		mm/s	105
	Lowering speed (with load) (负载下降速度)		mm/s	103
	Gradeability (without load) (无负载最大爬坡能力)		%	7
	Gradeability (with load) (负载最大爬坡能力)		%	6
	Service Weight (with battery) (重量含电池)		kg	880
	Dimensions (尺寸)	Overall length of frame (整车长度)	L	mm
Overall length of frame(with platform)(整车长度带踏板)			mm	2590
Overall width of frame (整车宽度)		B	mm	854
Overall height when mast lowered to lowest (门架降至最低整车高度)		H1	mm	2090
Overall height when mast lifted to highest (门架上升至最高整车高度)		H4	mm	2090
Wheelbase (轴距)		Y	mm	1420
Fork length (货叉长度)			mm	1150
Fork outside width (货叉外侧宽度)		B1	mm	680
Fork inside width (货叉内侧宽度)		B2	mm	300
Fork thickness (货叉厚度)		mm	65	

	Fork height when fork lowered to lowest (货叉降至最低高度)	S	mm	90
	Min ground clearance (最小离地间隙)		mm	15
	Theoretical width of minimum aisle for right-angle stacking (1200x1000) (直角堆垛通道最小理论宽度)	Asts	mm	2490
	Minimum turning radius (without platform) (不带踏板最小转弯半径)	Wa	mm	1813
	Minimum turning radius (with platform) (带踏板最小转弯半径)	Wa1	mm	2207
Tire (轮胎)	Front wheel (承载轮)		mm	85*70
	Drive wheel (驱动轮)		mm	250*80
	Caster wheel (平衡轮)		mm	130*55
	Wheel material (车轮类型)	polyurethane (聚氨酯)		
Electrical components (动力形式)	Drive motor type (驱动电机类型)	AC series motor (交流电机)		
	Rated output (功率)		kw	1.5
	Hoist motor type (起升电机类型)	DC series motor (直流电机)		
	Rated output (功率)		kw	2.2
Battery (电池)	Voltage (电压)		V	24
	Capacity (容量)		AH	160
	Weight (重量)		kg	150

Mast type (门架类型)	Max fork height (货叉最大高度)	Mast lowered (门架降低时高度)	Mast extended (门架延伸时高度)
	KLD20EC	KLD20EC	KLD20EC
Simplex or Duplex mast (2Stage)2级门架	2000	1480	2460
	2500	1730	2960
	3000	1980	3460
	3500	2230	3960
	4000	2480	4460

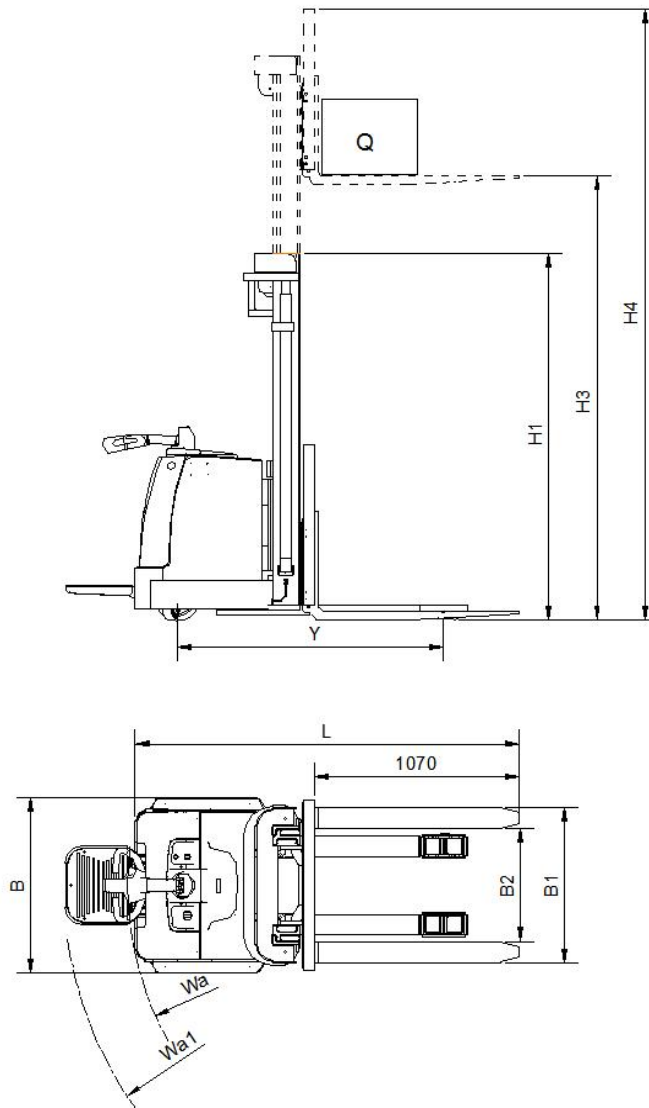

KLD30 电动堆垛车

Model (型号)				KLD30
Performance (性能)	Maximum load capacity(负载能力)		kg	3000
	load center (载荷中心距)	Q	mm	500
	Maximum lifting height (起升高度)	H3	mm	2500
	Travel speed (without load) (无负载行驶速度)		km/h	6
	Travel speed (with load) (负载行驶速度)		km/h	5.2
	Lifting speed (without load)(无负载起升速度)		mm/s	107
	Lifting speed (with load) (负载起升速度)		mm/s	62
	Lowering speed (without load) (无负载下降速度)		mm/s	54
	Lowering speed (with load) (负载下降速度)		mm/s	53
	Gradeability (without load) (无负载最大爬坡能力)		%	7
	Gradeability (with load) (负载最大爬坡能力)		%	6
	Service Weight (with battery) (重量含电池)		kg	1696
Dimensions (尺寸)	Overall length of frame (整车长度)	L	mm	2169
	Overall length of frame(with platform)(整车长度带踏板)		mm	2585
	Overall width of frame (整车宽度)	B	mm	1046

	Overall height when mast lowered to lowest (门架降至最低整车高度)	H1	mm	1934
	Overall height when mast lifted to highest (门架上升至最高整车高度)	H4	mm	3513
	Wheelbase (轴距)	Y	mm	1596
	Fork length (货叉长度)		mm	1070
	Fork outside width (货叉外侧宽度)	B1	mm	905
	Fork inside width (货叉内侧宽度)	B2	mm	655
	Fork thickness (货叉厚度)		mm	45
	Fork height when fork lowered to lowest (货叉降至最低高度)		mm	70
	Min ground clearance (最小离地间隙)		mm	20
	Theoretical width of minimum aisle for right-angle stacking (1200x1000) (直角堆垛通道最小理论宽度)	Asts	mm	2550
	Minimum turning radius (without platform) (不带踏板最小转弯半径)	Wa	mm	1893
	Minimum turning radius (with platform) (带踏板最小转弯半径)	Wa1	mm	2275
Tire (轮胎)	Front wheel (承载轮)		mm	85*95
	Drive wheel (驱动轮)		mm	260*105
	Caster wheel (平衡轮)		mm	130*55
	Wheel material (车轮类型)	polyurethane (聚氨酯)		
Electrical components (动力形式)	Drive motor type (驱动电机类型)	AC series motor (交流电机)		
	Rated output (功率)		kw	3
	Hoist motor type (起升电机类型)	DC series motor (直流电机)		
	Rated output (功率)		kw	3
Battery (电池)	Voltage (电压)		V	24
	Capacity (容量)		AH	210
	Weight (重量)		kg	195

Mast type (门架类型)	Max fork height (货叉最大高度)	Mast lowered (门架降低时高度)	Mast extended (门架延伸时高度)
	KLD30	KLD30	KLD30
Simplex or Duplex mast (2Stage)2级门架	2500	1934	3513
	3000	2184	4023
	3500	2434	4533
	4000	2684	5043

3. Location and description of safety devices and safety signs

(A) Location and description of the safety signs

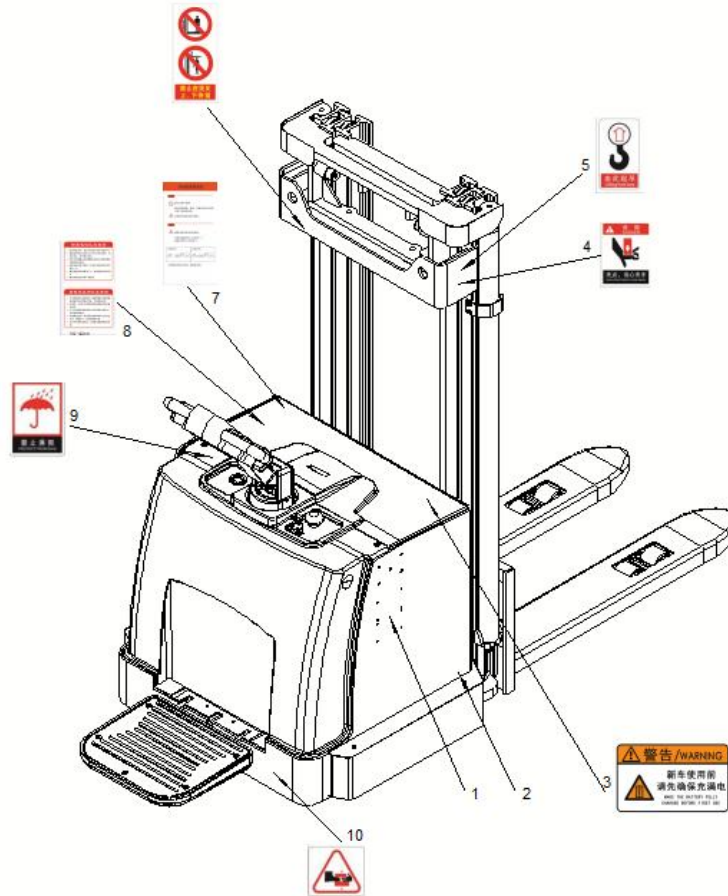

1	Nameplate	5	Lifting sign	9	No rain sign
2	Frame Number	6	Sign prohibiting forks from moving up and down	10	Beware of the pinched foot
3	New car charging sign before use	7	Charging machine identification		

4	Beware of the pinched hands	8	Battery maintenance mark		
---	-----------------------------	---	--------------------------	--	--

(b) Safety device

This stacker has a key switch (15) to stop all functions and fail the electromagnetic braking. After checking the function of the controller, pull up the switch to operate the stacker. Before the operation, manually enter the password to start the vehicle.

If you do not operate this stacker, to prevent unauthorized use, press the emergency stop switch (16)

This stacker is equipped with a belly switch (17). When the vehicle moves to the operator, if only by touching the belly switch within the operating range of the handle, the vehicle can drive in the direction of deviation from the operator.

(C) During the vehicle driving process, the boom should be opened. When the lifting height of the vehicle exceeds 1800mm, the arm should be folded up.

4. Storage and transportation

(a) Transport

Remove the goods during transportation, drop the fork to the lowest level and press the emergency stop switch and close the key switch. See the figure and secure the vehicle with professional lifting equipment;

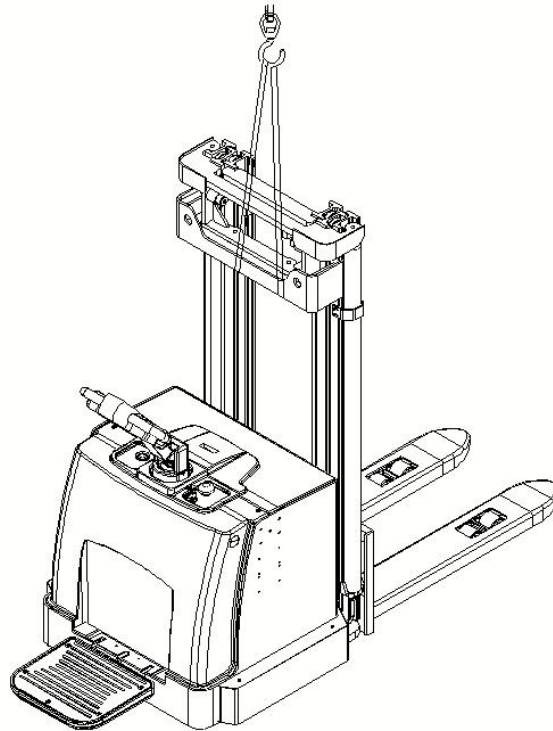

In the process of transportation, the stacker should be firmly fixed on the transport vehicle;

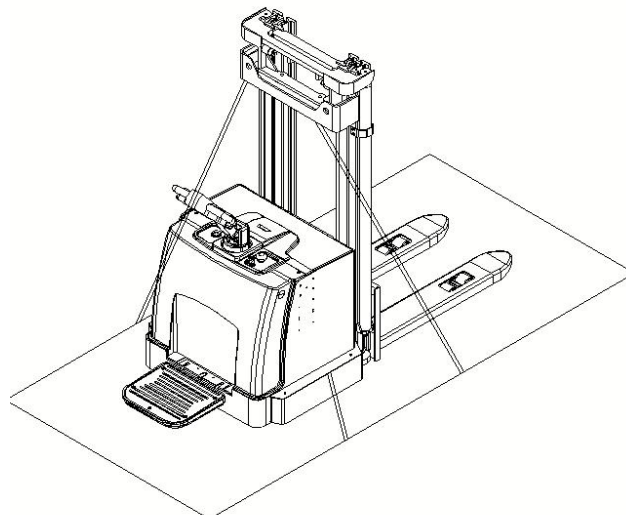

(b) Storage

Remove the goods during storage and reduce the vehicle to the lowest position. Press the emergency stop switch and turn off the key switch.

Note: For the first time after long-term storage, the vehicle performance must be checked and tested before use.

5. Description of the nameplate and the load curve

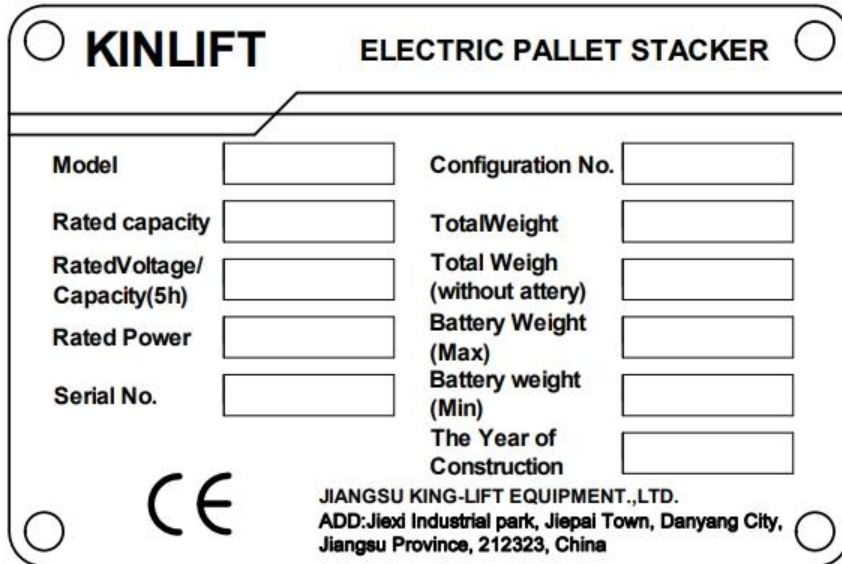

The configuration of each car may not be the same. Please be sure to check the nameplate to confirm its attributes before using it.

KLD-N Load Capacity Chart		
Lift Height (mm)	Load Center at 600mm(kg)	
	KLD15N	KLD20N
1600	1500	2000
2000	1500	2000
2500	1500	2000
3000	1500	2000
3500	1300	1700
4000	1000	1400
4500	900	1000
5000	750	800
5500	650	700
6000	300	400

When the height of the lift increases, the load capacity of the vehicle decreases accordingly. The load plot represents the rated lifting weight for the different lifting heights.

(1) The configuration of the vehicle changes with the customer's order. Before using the vehicle, please check the load curve diagram to confirm the carrying capacity of the vehicle.

(2) The curve parameters on the load curve diagram shall correspond to the compact and uniform cargo, and shall not exceed the load limit. Otherwise, the shadow

Stability of the vehicle and strength of related parts.

6. Operation declaration

Pilot lever

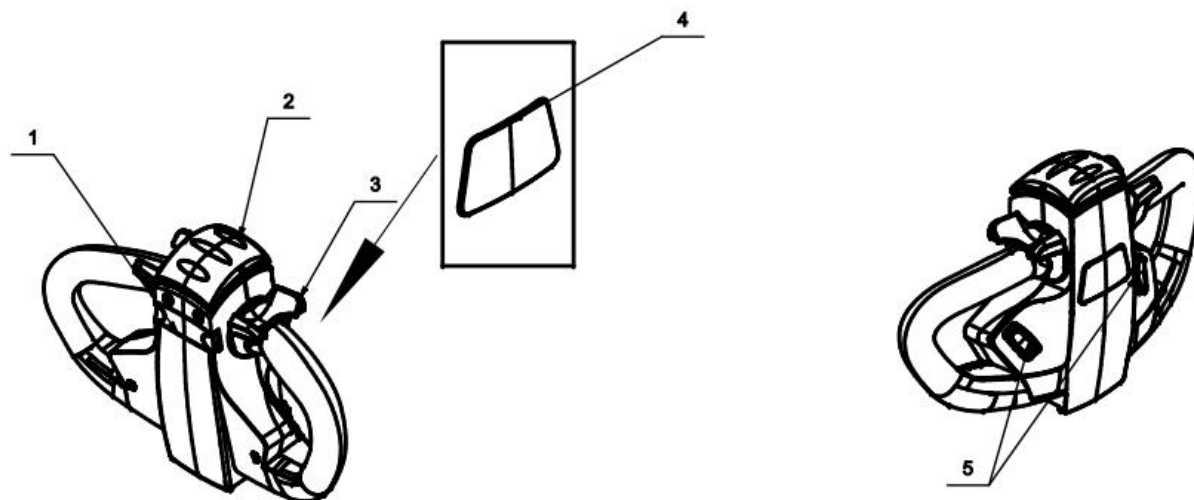

1	Turtles speed switch	4	horn switch
2	Emergency stop reverse switch	5	Lifting switch
3	Handle accelerator		

ID card operation

If the car is equipped with an ID card, close the ID card to the password lock button panel. If the ID card is a valid ID card, the password lock will sound a brief beep, and then the green indicator light is always on, indicating that the password lock is working normally.

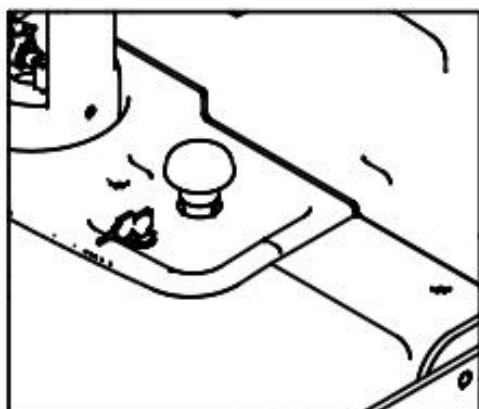

Power is switched on or off

Rotate the key switch to the right and start the forklift to the left.

Note: The emergency stop switch must be removed to start the forklift

This forklift is equipped with two electric lock keys, one for driving and the other for backup. The spare electric lock key is recommended to be stored separately to opening the forklift when the main key is lost or cannot be found.

Emergency stop

When the emergency stop button is pressed, the forklift is power off; pull up the emergency stop button and the forklift.

Steering

Turn the control handle to turn the forklift while driving.

Walking and braking

(A) The speed governor is used to control the walking speed, and the stepless speed adjustment makes the operation safer and more accurate.

(B) Turn on the emergency stop switch, choose the driving direction correctly, and slowly accelerate to the ideal speed.

(C) Release the rotary switch, lift or drop the operating handle to the lowest or highest position, and the vehicle is braked.

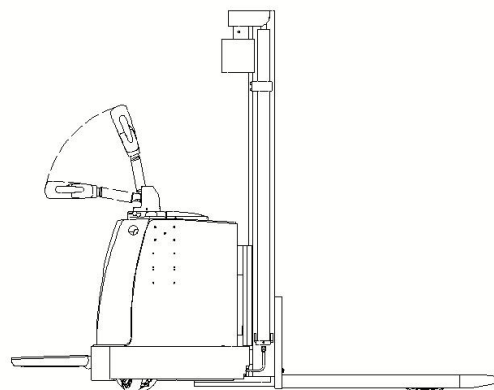

Horn switch

Press the button to horn the horn.

Emergency reverse with the turtle speed button

When the vehicle is moving towards the operator, simply pressing the belly switch within the operating range of the handle can drive the vehicle in the direction of the operator.

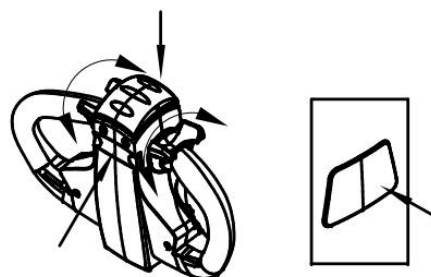

When the vehicle is running normally, press the turtle speed button while moving the handle accelerator, and the vehicle enters the turtle speed mode and drives slowly.

Lifting up and lowering down

- 1、 Press the lifting and lowering button to control the lifting and lowering of the forklift mast.
- 2、 Such stacks are only used for smooth, smooth ground. The cargo fork shall not be higher than 200mm when walking.
- 3, because from the safety point of view, when stacking, should be as

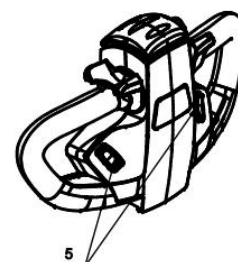

short as possible slow walk.

4, no overload and heavy overload.

Battery charging

1. Charger parameters: see the charger specification for details
2. Place the key switch in the shutdown position, press the red emergency stop button, plug the plug on the charger with the battery power plug, and start charging.

When the charging is over, disconnect the power terminal connector first. The above order can not be violated.

3. The adjustment of the charger current is determined according to the battery capacity.
4. It is necessary to avoid sparks, open flame, thermal radiation and ventilation when charging.

3. safe code

Summary

1. Before using the forklift every day, all safety switches and equipment should be checked in advance to ensure that these safety facilities are in good condition.
2. Check that all warning and design parameter signs on the board are not damaged.
- 3, if the stacking forklift is damaged or the fault affects the safe use, the use is prohibited.
- 4, the forklift truck in the maintenance or adjustment, should be responsible for by the professional personnel.

Forklift operation

In a certain range of use height, the forklift truck can be raised and lifted freely. Special manufacturing must be made for forklifts used in freezers. For the design and manufacture:

- 1, the air contains flammable and explosive dust or gas occasions.
- 2, as a tractor for other cars.
3. To transport or lift people.

Responsibilities of the operator

1. The forklift can be operated after training and approval.
2. Abide by this manual and relevant local safety regulations, rules, and traffic rules.
- 3, the hands and feet with oil, it is strictly prohibited to operate the forklift truck.

Operational site

1. Stacking forklifts can only operate on smooth, hard pavement, such as concrete or asphalt pavement. Do not work in oil pollution areas to avoid slipping.
2. Ensure that the ground can withstand the total weight of the stacking forklift, that is, the dead weight of the forklift, the load weight and the weight of the operator.
3. Operation guidance during driving:
 - (A) No sudden brake or turn is allowed at high speed.
 - (B) Keep the cargo in the position.
 - (C) Slow down on the slope, keep the goods in the lowest position, and prohibit lifting the raised head or fork on the slope during driving.
 - (D) If the road slips, slow down to prevent the forklift from idling or overturning.
 - (E) Except for the loading and unloading of goods, the cargo fork shall fall at a height of no more than 200mm off the ground during driving. Do not lift and rotate the cargo simultaneously.

4. If the view is blocked, please ask others to guide around to ensure safety.
5. Keep a safe distance from the vehicles, personnel and objects in front of you
6. the horn should sound when speeding.
7. Stacking forklift is not used to transport personnel.
8. Before the forklift enters the elevator, ensure that the elevator can withstand all the weights.
9. Loading and unloading of goods:
 - (A) Only when loading and unloading goods, can operate the handle and keep a distance from the surrounding personnel. Do not lift the handle, and ensure that the height of the handle from the ground does not exceed 200mm.
 - (B) The loaded and unloaded goods shall be kept equal at the left and right positions on the fork, unstable or unsafe and not allowed for transportation.
 - (C) When the cargo rises, never touch the gantry to prevent clip injury.
 - (D) Can only load and unload the cargo within the maximum lifting weight and load center allowed by the forklift, and adjust the cargo according to the external size of the fork. See the loading curve for more details.
 - (E) Special care shall be taken when loading and unloading excessive and excessive loads. Handling and unloading goods with high height, the forklift shall be equipped with block shelves.
10. Parking precautions:
 - (A) After the forklift truck stops stable, the cargo fork should be placed to the lowest point.
 - (B) Forklifts are prohibited from parking on the slope.
 - (C) The forklift is parked at the designated place.
 - (d) Forklifts are not parked at the emergency exit.
 - (E) Forklift trucks are prohibited from stopping in places that hinder work.
 - (f) The power must be turned off after parking.

4. Battery

Replace the battery

Only replace with the original battery model, the weight of the battery.(The weight of the battery affects the stability and braking function of the forklift.)

Pay attention to!

Do not change the weight and size of the battery arbitrarily, otherwise it will affect the center of gravity of the car body. The heavy or light weight of the battery will affect the stability and braking capacity of the forklift, and its weight must be consistent with the value on the forklift sign.

1. Remove the battery:

- (a) Pull out of the power supply connector.
- (b) Open the battery box lid.
- (c) Disconnect the battery from the car body cable.
- (d) Use the appropriate battery box and remove the battery pack from the forklift.

2. The sequence of the battery replacement:

- (a) Use the lifting device to lift the battery battery pack and put it into the battery box of the forklift.
- (b) The battery connector is connected to the car body cable connector.
- (c) Close the battery box lid.

Charge

No smoking or using an open flame when charging. Charge the battery and use an automatic charger.

Pay attention to!

The battery electrolyte contains dilute sulfuric acid, which is corrosive. If you splash on the skin, rinse with water and soap as soon as possible. Contact your eyes. When checking the battery, wear protective glasses and gloves.

3. Charging preparation

The forklift truck battery must be charged after use, and the storage time shall not exceed 24 hours.

- (a) After parking, put the key switch in the closing position and pull out the key.
- (b) Ensure ventilation above the battery and open the battery vent cover.
- (c) Pull out the power socket and plug on the charger with the battery power plug.
- (d) Turn on the AC and charge the charger.

pay attention to!

During charging, especially in the closed area. In the process of charging, there is hydrogen and oxygen in the battery, when the open fire, electric spark will cause explosion!

Therefore, before pulling out the power socket, you should cut off the charging power supply.

4. Charging period

The following methods can be used to determine the adequacy of power during charging:

- (a) The specific gravity of the electrolyte of the battery remains stable for more than 2~3 hours continuously.
- (b) The electrolyte surface in the battery produces strong bubbles, and the electrolyte turns from milky white to bright.

The above situation indicates that the battery power is sufficient.

5. After sufficient

- (a) Turn off the AC power supply and the battery charger.
- (b) Unplug the charger plug.
- (c) insert the battery power outlet into the forklift end plug and place the key switch off.
- (d) Close the air permeability cap on the battery.

The comparison table of the temperature and electrolyte when the battery is sufficient is as follows:

temperature ° C	Specific gravity, g / cm ³
-15	1.31
0	1.30
+15	1.29
+30	1.28
+45	1.27

If it does not meet the specific gravity in the table, add acid or distilled water for adjustment.

Battery maintenance

1. In order to ensure the life of the battery, the battery should be fully charged before put into use, the battery can not be used.
2. The battery should try to avoid overcharge or overdischarge. Overcharge or overdischarge will seriously affect the performance and life of the battery.
3. The battery liquid hole plug and breathable cover should be kept clean, removed or opened when charging, and should be installed or closed after charging. The battery surface, connecting connections and screws shall be kept clean and dry. If there is sulfuric acid, with cotton yarn dipped in the lye to wipe

away, pay attention not to let the lye into the battery.

4. After charging, the liquid level of the battery should be checked and distilled water should be added to maintain the height of the liquid level. Under normal circumstances, dilute sulfuric acid.

5. The battery after use, should be charged in time, the placement time is generally not more than 24 hours.

6. Good ventilation should be maintained when charging, and fireworks are strictly prohibited.

7. In the following cases, the battery needs to be balanced charging.

(A) The battery in normal use (make a balanced charge every 3 months).

(B) shelve the unused battery for a long time.

(C) There is a "backward battery" in the battery group (the backward battery refers to the battery whose voltage value is lower than that of other batteries in the process of charging and discharging, or which has been repaired due to failure). At this time, the balanced charging is only for the backward battery separately.

8. Balanced charging method.

(a) Normal charging is performed first.

(b) Stop charging for 1 hour when the power state is sufficient, and then charge with 0.25c for 1 hour.

Repeat several times until the charger closes, there are bubbles in the battery.

9. When the battery is not used, the storage period shall be replenished once according to the ordinary charging method.

10. the battery should avoid direct sunlight, and the distance from the heat source shall not be less than 2M.

11. avoid contact with any liquid and harmful substances, any metal impurities shall not fall into the battery.

5. Debugging

Order number	Hitch	Cause	Processing method
1	The fork can't rise The highest height	-The hydraulic oil is not enough	-Filling hydraulic oil
2	The fork cannot rise	-No hydraulic oil -Hydraulic oil is not pure	-Filling hydraulic oil -Replace hydraulic oil
3	Pump station motor Can't run	-The emergency switch is not turned on -Battery voltage is too low -Power cord connector is loose -Damaged motor contactor	-Lift up the emergency switch — charge — screw home — change for new
4	The fork cannot drop	-Deformation of the piston rod or cylinder block caused by the cargo bias to one side or overload. -The fork stops at a high position for a long time, causing the piston rod to expose and rust for a long time, blocking the movement of the piston. -The release valve of the hydraulic pump station cannot be opened due to wear or damage.	-Replace the piston rod or cylinder block -Please drop the fork to the lowest position when not in use, and pay attention to lubricate the piston rod. — Replace the release valve of the pump station

5	oil leak	-Seals are aged or damaged -Component rupture	— change for new — change for new
6	The fork from the drop	-The hydraulic oil impurity causes the release valve not to be closed -Seals are aged or damaged -The release valve is damaged	-Replace hydraulic oil — change for new — change for new
7	storage battery Can't charge	-Battery damage - -The charging plug is loose	— change for new -Plug in

Note: Self-maintenance is strictly prohibited without authorization or training.

6. Maintenance

After 500 hours of operation, a routine maintenance should be carried out. The efficiency, life and safety of the forklift truck depend on the daily maintenance.

Repair of forklift truck and replacement of accessories shall be provided by the company to ensure quality. It is recommended to contact the product agent or the after-sales service department of the company. To make your forklift truck can run more safely and economically.

Safety rules for the maintenance work

Only through systematic learning can the maintenance work be carried out.

1. Keep the maintenance site clean and hygienic.
2. During maintenance, do not carry loose items and valuables.

Pay attention to!

To repair the forklift electrical system and prevent short circuit or combustion, remove the watch, earrings or metal trim.

3. Before the forklift maintenance, you should first unplug the power socket, disconnect the power supply.
4. Before opening the back cover, put the key switch in the closing position and press the emergency stop switch.
5. Before checking the hydraulic system, the cargo fork should be lowered to release the system pressure.
6. When checking the oil leakage condition of the car body, do not contact it directly with your hands to avoid scalding.
7. The oil temperature in the transmission device or hydraulic system may be high, so the gear oil or hydraulic oil should be replaced after the forklift truck is cooled to prevent the high oil temperature from causing combustion.
8. The hydraulic system should be filled with a new hydraulic oil. It is recommended to use the no. 46 hydraulic oil.

Pay attention to!

Hydraulic oil is not clean will affect the precision hydraulic components, so that the entire hydraulic system capacity is reduced. The use of different grades of hydraulic oil damages the hydraulic components and also affects the system capability. Therefore, when adding or replacing hydraulic fluid, pay attention to use the uniform number.

9. Please abide by the relevant laws and regulations, protect the environment, store and discharge oil according to the regulations, and prohibit to discharge it into the sewer pipe.

10. If there is a welding requirement for the car body, in order to prevent the welding current from entering the battery, please cut off the power supply.

11. In the absence of reliable support, all parts of the human body can not enter the forklift gantry or fork below.

Pay attention to!

Improper support, the forklift will dump and hurt people. If the forklift is not protected by lifting equipment or support, it is prohibited to work under the forklift.

Maintenance work that the user can complete

Daily maintenance and safety inspection:

1. It is the operator's responsibility for the routine maintenance and inspection of forklift trucks.
2. forklift does not carry out daily maintenance, will affect the safety and reliability of forklift, easy to lead to serious accidents.
3. Check out the problem or found the fault should immediately stop using and start to repair.
4. In order to maintain a good use state, necessary inspection and maintenance of the vehicle every day.

At this time, inspection should be emphasized:

Site number	check point	scope of examination
1	operation control	Check that it is not properly functional
2	Belly switch	Check that it is not properly functional
3	suona	Check that it is not properly functional
4	turn	Check that it is not properly functional
5	hydraulic unit	Check that it is not properly functional
6	coulombmeter	Check that it is not properly functional
7	hydraulic pressure system	Check the oil level and check for oil leakage
8	actuating device	Check for any abnormal noise and oil leakage
9	brake coupling	Check for normal operation and poor contact

10	transmission	Check that it is not properly functional
11	wheel	Check for any damage and remove oil stains and metal debris
12	frame	Check whether there is any damage and remove the oil pollution
13	Goods fork	Check for any deformation or cracks
14	hydraulic jack	Check for any damage and oil leakage

Clean forklift

Routine cleaning is performed weekly and is important to ensure its reliability. Pay attention to unplug the power socket before cleaning to avoid damage to electrical system caused by short circuit.

External cleaning:

1. Remove the attachments to the wheels every day to maintain flexible rotation.
2. When cleaning the electrical components, compressed air should be used to clean the motor dust. The dust in the line should not be wiped with a wet cloth.
3. After the cleaning is completed, add lubricating grease to the main parts.

Pay attention to!

During cleaning, the electrical components cannot be washed with high pressure flushing device, and the electrical components on the circuit board cannot be damaged to avoid short circuit.

7. Schematic diagram

Electrical schematic diagram

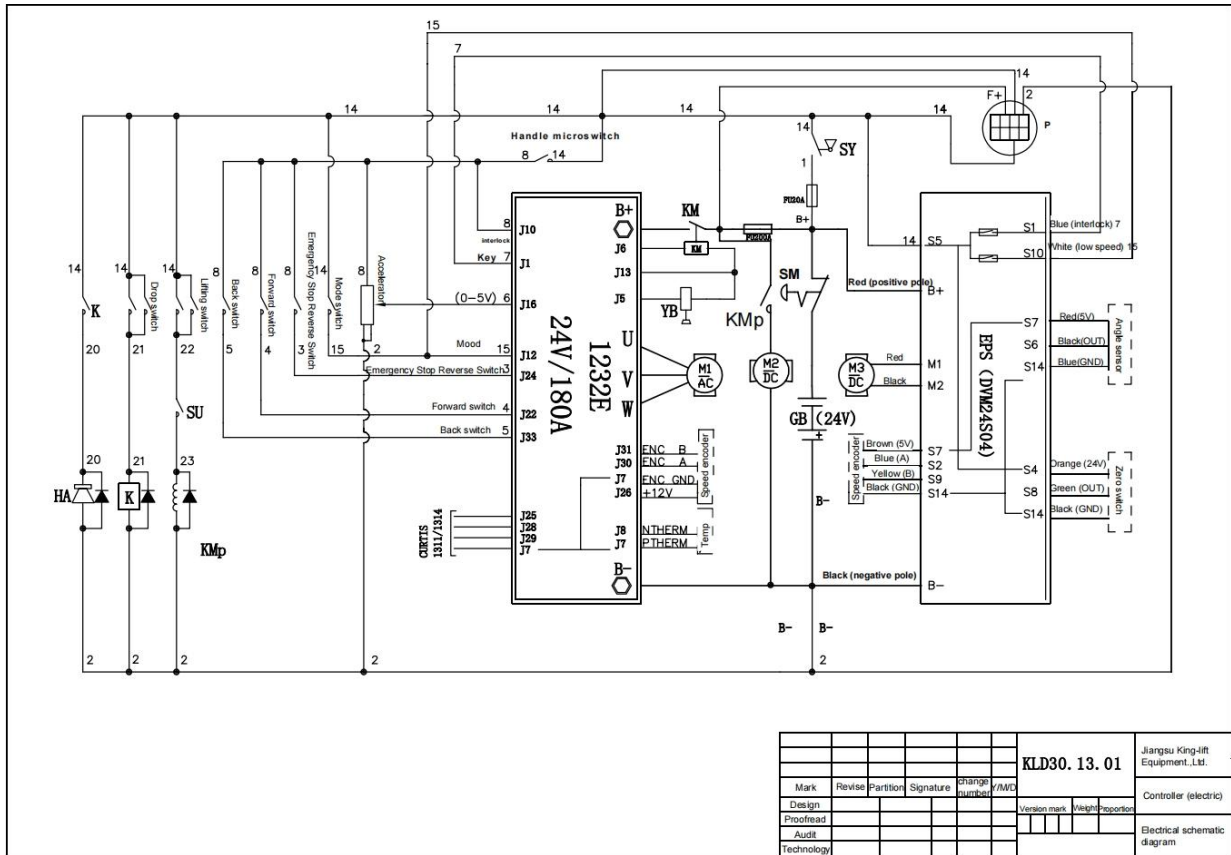

(KL D-N)

Hydraulic schematic diagram

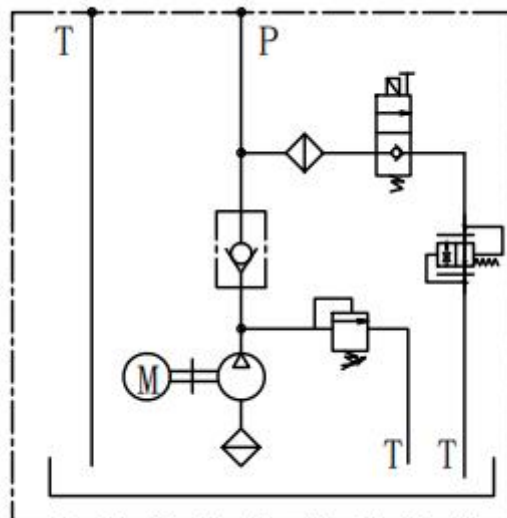

Brake schematic diagram

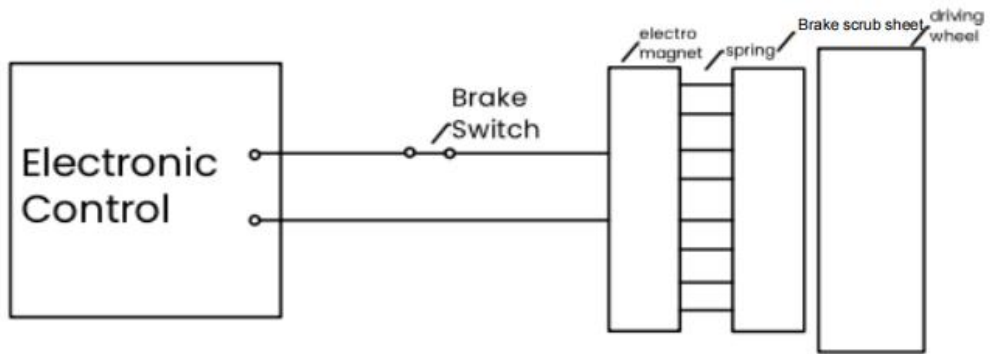

Full vehicle condition

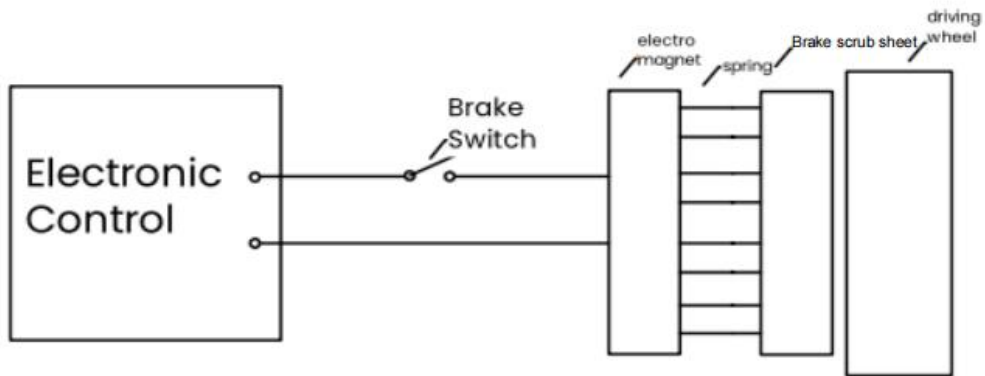

Parking brake condition