

ELECTRIC PALLET TRUCK -KLT



APPLICABLE FOR SINGLED-FACED AND DOUBLE-FACED PALLET



BRIEF INTRODUCTION OF PRODUCT:

1. EPS STEERING SYSTEM LESSENS THE STEERING FORCE, INCREASING THE SENSITIVITY, IMPROVING THE PERFORMANCE OF STEERING REVERSAL, SO THE VEHICLE SLOWS DOWN AUTOMATICALLY ON THE CURVE AND BE EASY AND SAFE TO OPERATE.
2. AC MOTOR OF VERTICAL DRIVE IS NO CARBON BRUSH, HAVING BETTER STARTABILITY ON THE RAMP PLUS REGENERATIVE BRAKING, WHICH EFFECTIVELY INCREASES THE WORK EFFICIENCY AND SERVICE DURATION OF ELECTRIC MOTOR PLUS MORE ENERGY-SAVING.
3. CONFIGURED WITH ZAPI CONTROLLER, ALBRIGHT CONTACTOR, WATER-PROOF AMP CONNECTOR ASSEMBLY OF POWER SUPPLY.
4. WITH PECULIAR TECHNOLOGY OF SHOCK ABSORPTION OF DRIVE, WHICH ENABLES THE TRAFFIC-ABILITY MORE SUPERIOR.
5. TWO OIL CYLINDERS ARE EQUIPPED TO IMPLEMENT THE SYNCHRONIZED LIFTING FUNCTION, ADDITIONALLY CUT OFF POWER SUPPLY AUTOMATICALLY AT THE TOP LIFTING HEIGHT.
6. DRIVEN ON A STAND-UP PLATFORM THAT IS WITH SHOCK ABSORPTION.

OPTIONAL CONFIGURATION:

1. SPECIAL CONFIGURATION FOR REFRIGERATED STORAGE
2. NON-STANDARD FORKS
3. HIGH-CAPACITY BATTERY 300 AH
4. RING PROFILE SPECIAL PALLET TRUCK CUSTOMIZATION
5. ABLE-DISMANTLED PROTECTIVE ARMREST
6. LI-ION BATTERY

	Model(型号)		KLT20	KLT25	KLT30
Performance (性能)	Maximum load capacity (负载能力)	kg	2000	2500	3000
	load center (载荷中心距)	Q mm	600	600	600
	Maximum lifting height (起升高度)	H3 mm	120	120	120
	Travel speed (without load) (无负载行驶速度)	km/h	5.5	5.5	5.5
	Travel speed (with load) (负载行驶速度)	km/h	5	5	5
	Lifting speed (without load) (无负载起升速度)	mm/s	50	50	50
	Lifting speed (with load) (负载起升速度)	mm/s	30	30	30
	Lowering speed (without load) (无负载下降速度)	mm/s	57	57	57
	Lowering speed (with load) (负载下降速度)	mm/s	57	57	57
	Gradeability (without load) (无负载最大爬坡能力)	%	7	7	7
Gradeability (with load) (负载最大爬坡能力)	%	6	6	5	
Service Weight (with battery) (重量含电池)	kg	685	685	685	
Dimensions (尺寸)	Overall length of frame (整车长度)	L mm	1775	1775	1775
	Overall length of frame(with platform)(整车长度带踏板)	mm	2280	2280	2280
	Overall width of frame (整车宽度)	B mm	735	735	735
	Wheelbase (轴距)	Y mm	1417	1417	1417
	Fork length (货叉长度)	mm	1150	1150	1150
	Fork outside width (货叉外侧宽度)	B1 mm	685	685	685
	Fork inside width (货叉内侧宽度)	B2 mm	345	345	345
	Fork thickness (货叉厚度)	mm	60	60	60
	Fork height when fork lowered to lowest (货叉降至最低高度)	S mm	85	85	85
	Min ground clearance(最小离地间隙)	mm	5	5	5
Theoretical width of minimum aisle for right-angle stacking (1200x1000) (直角堆垛通道最小理论宽度)	Asts mm	2312	2312	2312	
Minimum turning radius (without platform) (不带踏板最小转弯半径)	Wa mm	1625	1625	1625	
Minimum turning radius (with platform) (带踏板最小转弯半径)	Wa1 mm	2135	2135	2135	
Tire (轮胎)	Front wheel (承载轮)	mm	85*70	85*70	85*70
	Drive wheel (驱动轮)	mm	230*75	230*75	230*75
	Caster wheel (平衡轮)	mm	130*55	130*55	130*55
	Wheel material (车轮类型)		polyurethane (聚氨酯)		
Electrical components (动力形式)	Drive motor type (驱动电机类型)		AC series motor (交流电机)		
	Rated output (功率)	kw	1.5	1.5	1.5
	Hoist motor type (起升电机类型)		DC series motor (直流电机)		
	Rated output (功率)	kw	0.8	1.2	1.2
Battery (电池)	Voltage (电压)	V	24		
	Capacity (容量)	AH	210		
	Weight (重量)	kg	195		

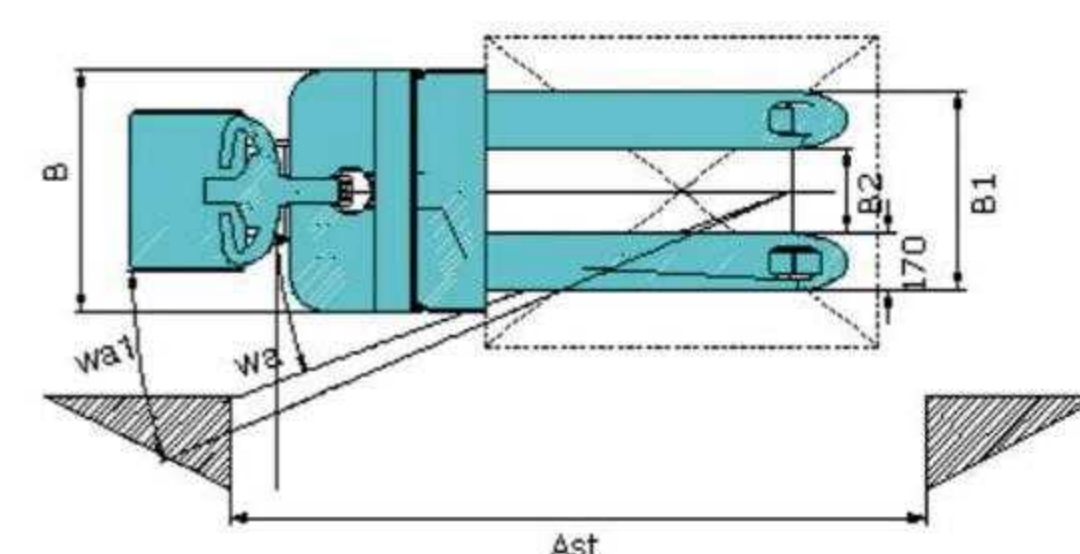
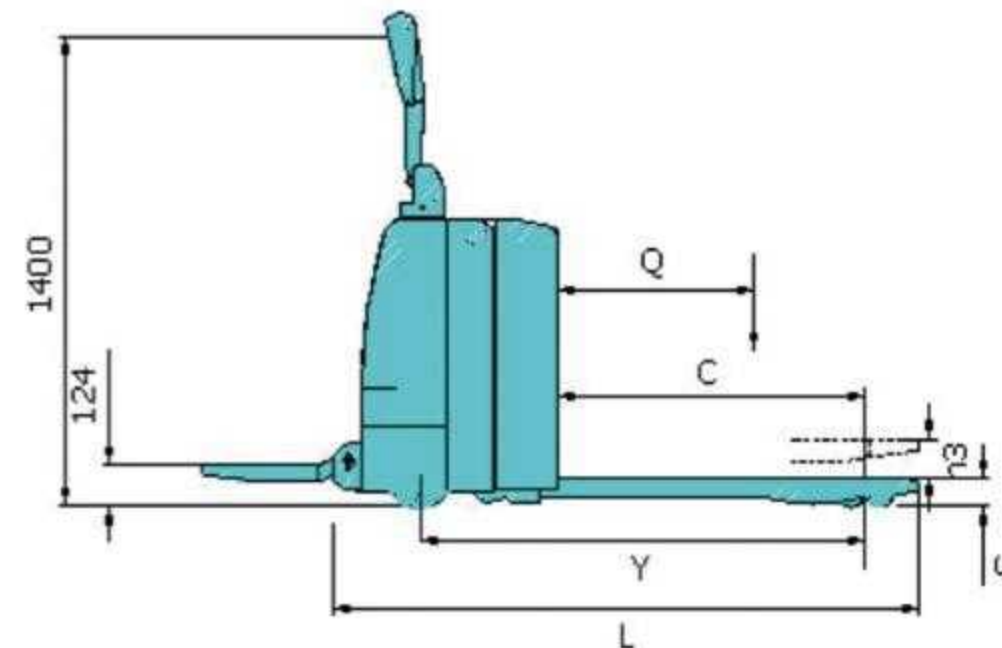

KLT30D



APPLICABLE FOR BOTH SINGLE-FACED AND DOUBLE-FACED PALLET



	Model(型号)		KLT30D
Performance (性能)	Maximum load capacity (负载能力)	kg	3000
	load center (载荷中心距)	Q mm	600
	Maximum lifting height (起升高度)	H3 mm	120
	Travel speed (without load) (无负载行驶速度)	km/h	5.5
	Travel speed (with load) (负载行驶速度)	km/h	5
	Lifting speed (without load) (无负载起升速度)	mm/s	25
	Lifting speed (with load) (负载起升速度)	mm/s	20
	Lowering speed (without load) (无负载下降速度)	mm/s	25
	Lowering speed (with load) (负载下降速度)	mm/s	40
	Gradeability (without load) (无负载最大爬坡能力)	%	5
Gradeability (with load) (负载最大爬坡能力)	%	3	
Service Weight (with battery) (重量含电池)	kg	655	
Dimensions (尺寸)	Overall length of frame (整车长度)	L mm	1995
	Overall length of frame(with platform)(整车长度带踏板)	mm	2414
	Overall width of frame (整车宽度)	B mm	782
	Wheelbase (轴距)	Y mm	1465
	Fork length (货叉长度)	mm	1150
	Fork outside width (货叉外侧宽度)	B1 mm	680
	Fork inside width (货叉内侧宽度)	B2 mm	340
	Fork thickness (货叉厚度)	mm	65
	Fork height when fork lowered to lowest (货叉降至最低高度)	S mm	85
	Min ground clearance(最小离地间隙)	mm	5
Theoretical width of minimum aisle for right-angle stacking (1200x1000) (直角堆垛通道最小理论宽度)	Asts mm	2360	
Minimum turning radius (without platform) (不带踏板最小转弯半径)	Wa mm	1770	
Minimum turning radius (with platform) (带踏板最小转弯半径)	Wa1 mm	2170	
Tire (轮胎)	Front wheel (承载轮)	mm	85*70
	Drive wheel (驱动轮)	mm	250*80
	Caster wheel (平衡轮)	mm	130*55
Electrical components (动力形式)	Wheel material (车轮类型)		polyurethane (聚氨酯)
	Drive motor type (驱动电机类型)		AC series motor (交流电机)
	Rated output (功率)	kw	1.5
	Hoist motor type (起升电机类型)		DC series motor (直流电机)
Battery (电池)	Rated output (功率)	kw	1.2
	Voltage (电压)	V	24
	Capacity (容量)	AH	160
	Weight (重量)	kg	150